

# 1.1" (27,94) RIGID TRANSLATOR PINS

## .035" (0,89) BODY WITH .048" (1,22) TIP

AVAILABLE IN THE FOLLOWING TIP STYLES



GI-I-035-048 CH  
.048" (1,22) Ø  
CHISEL TIP



GI-I-035-048 BU  
.048" (1,22) Ø  
BULLET TIP



GI-I-035-048 CO  
.048" (1,22) Ø  
CONICAL TIP

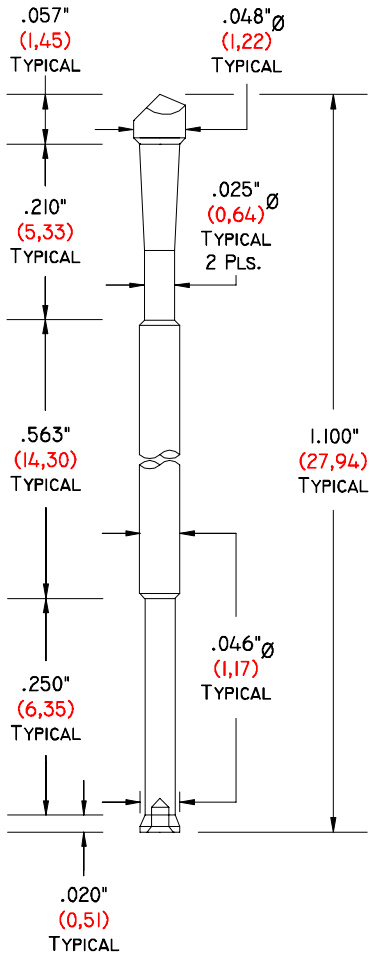

MATERIAL: HARD BRASS.

PLATING: ELECTROLESS NICKEL STANDARD ( -N ).  
GOLD OVER ELECTROLESS NICKEL OPTIONAL ( -G ).

OUR PART NUMBERS DESCRIBE THE DIMENSIONS OF THE PART

EXAMPLE:

GI-I-035-048 CH -N



### RECOMMENDED FIXTURE DRILL SIZES

BODY DIA.	TOP PLATE DRILL DIA.	THICK DIA.	BASE / GRID PLATE DRILL DIA.	THICK DIA.
.035"	1.15MM	.0453"	#49	.073"